

NOTE:-
MOC:- S.S. 304
FINISH:- IN SIDE & OUT SIDE
MAT FINISH.

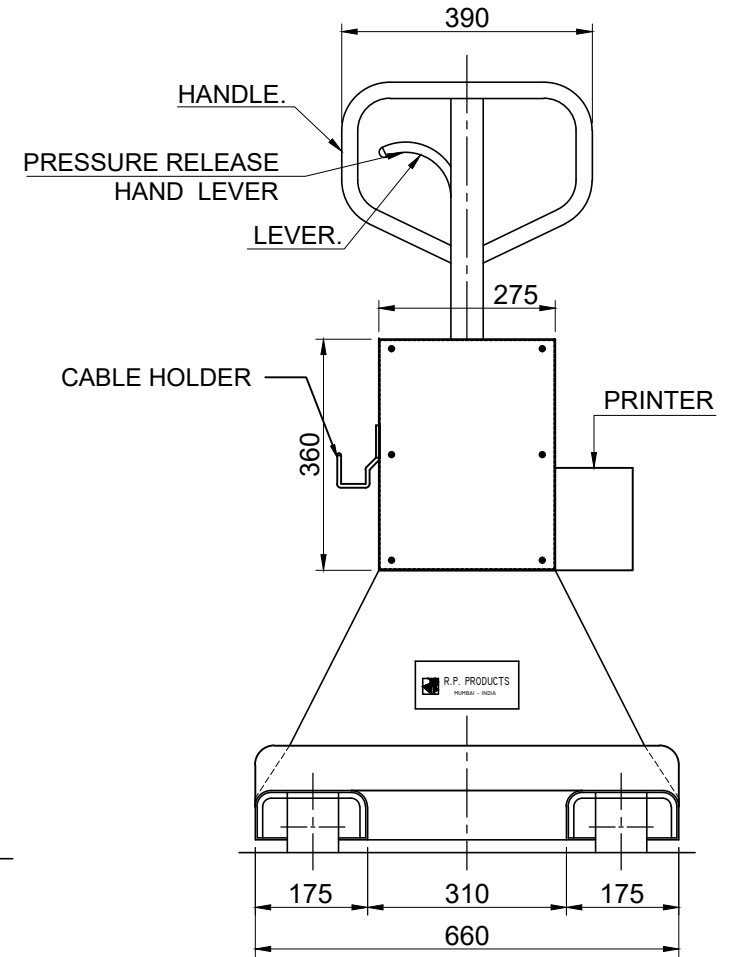
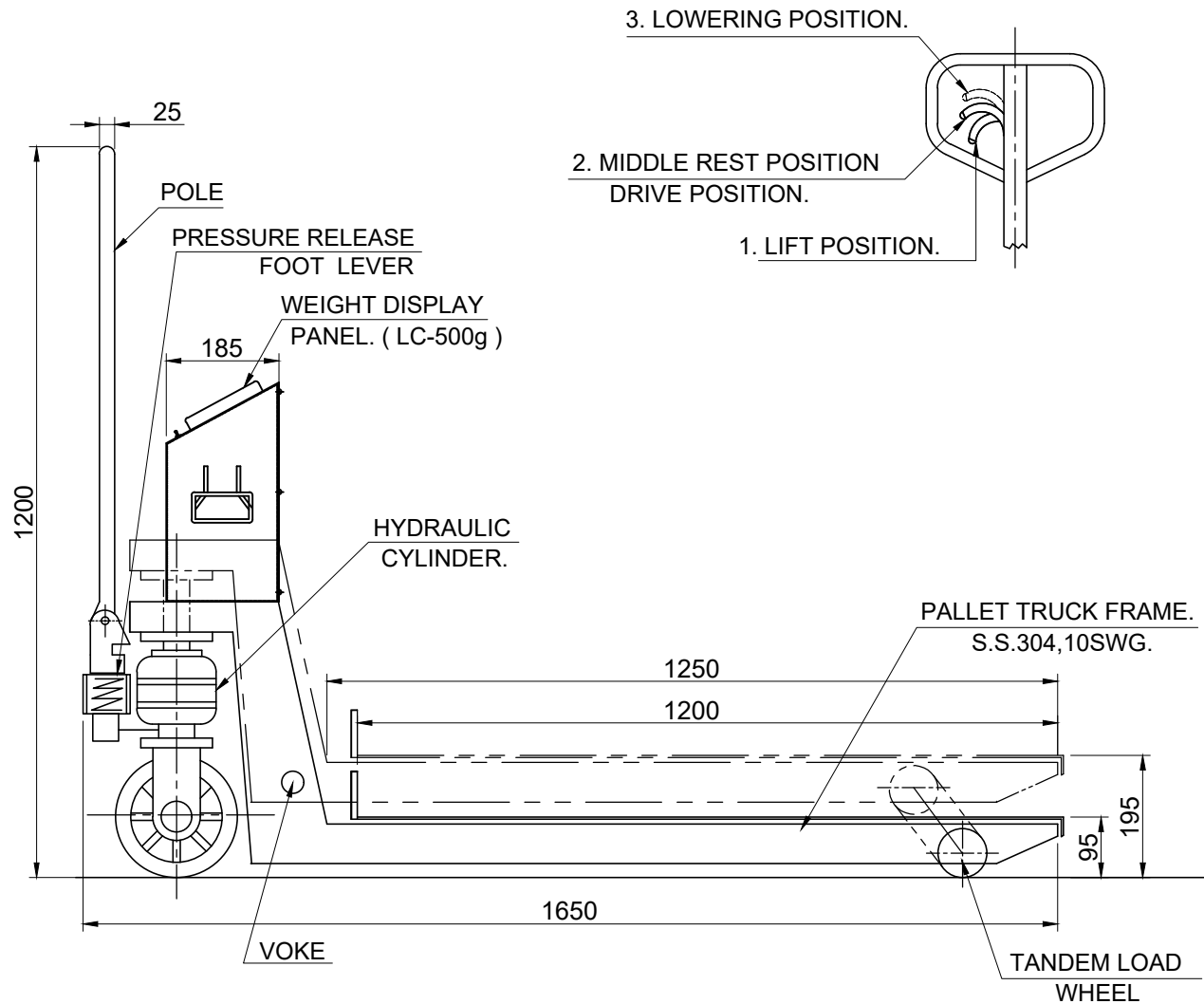

SR. NO.	REVISION	NOTE	DATE	DRN	CKD	DRAWN	PRATIK.	26.06.2019	SCALE	TITLE :	
						CHECKED				S.S. WEIGHT TRUCK.	
						APPROVED					
JOIST-O-MECH ENGINEERING PVT. LTD. NAVI MUMBAI - INDIA										CLIENT :	M/S. DR. REDDY.
										PROJECT :	
										DRG. No. :	RPP-STD-10431-00.