

6 5 4 3 2 1

**TECHNICAL SPECIFICATION:-**

- CAPACITY - 100 KGS.**
- MIN. HIEGHT - 500 MM**
- MAX HIEGHT - 2000 MM**
- MANUAL PUMP**

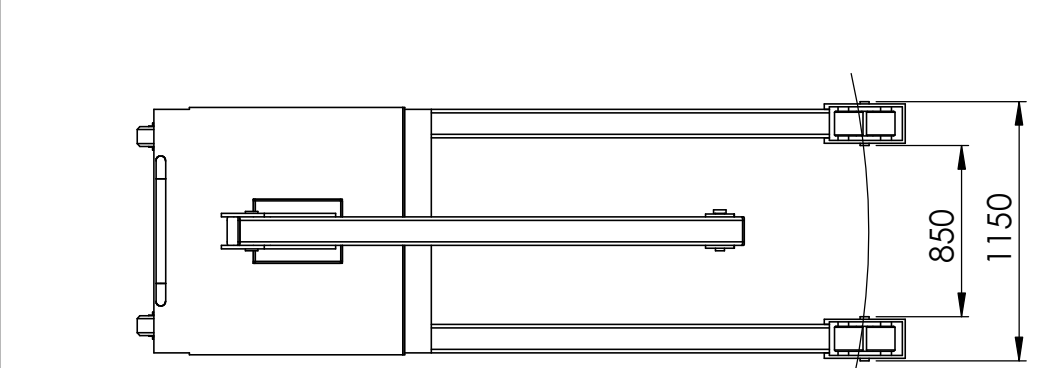
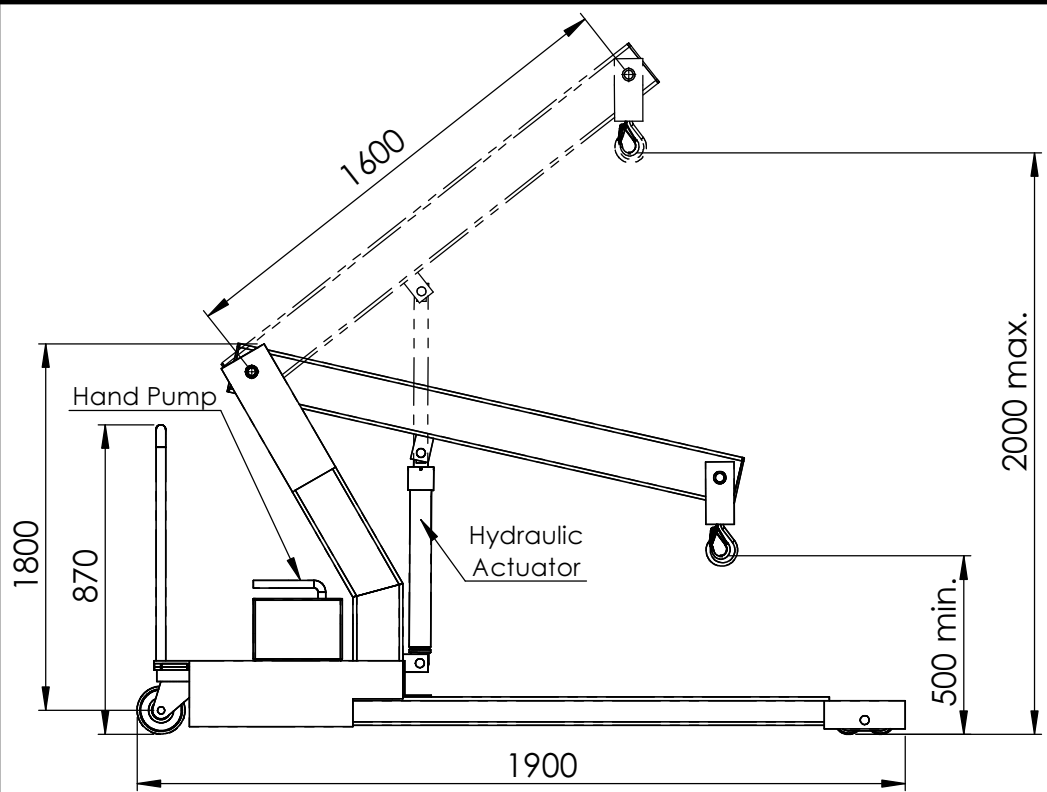

UNLESS OTHERWISE SPECIFIED:  
 DIMENSIONS ARE IN MILLIMETERS  
 SURFACE FINISH:  
 TOLERANCES:  
 LINEAR:  
 ANGULAR:

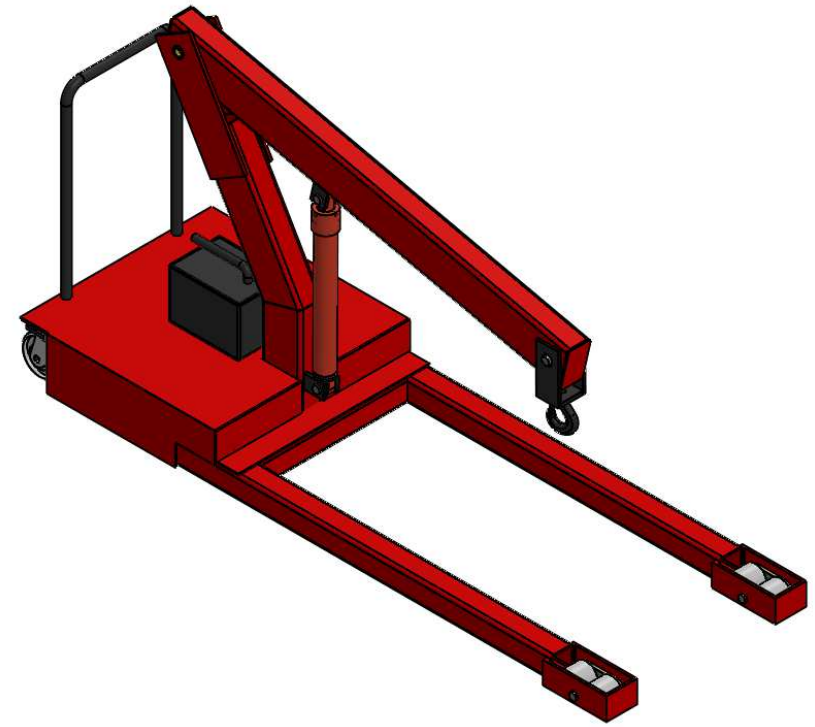

DEBURR AND BREAK SHARP EDGES	<b>JOIST - O- MECH</b>	
Drawn : Krishna	<b>TITLE:</b> Floor Crane	
Checked: K.T		
Approved :		
WEIGHT:	DWG NO. <b>3007</b>	A4
SCALE:1:20		SHEET 1 OF 1

6 5 4 3 2 1

D  
C  
B  
A

D  
C  
B  
A