

MOC : M.S.
 SURFACE FINISH : PU ENAMEL SPRAY PAINTED
 COLOUR : GOLDEN YELLOW
 AUTO AND INCHING MODE LIFTING OPERATION.

LOCATION: INDOOR /OUTDOOR

CAPACITY	C	1500 kg
PLATFORM LENGTH	L	2400 mm
PLATFORM WIDTH	W	1600mm
MOTOR HP	M	5 HP
MIN HEIGHT	H1	1700 mm
MAXIMUM HEIGHT	H2	3000 mm
LIFT HEIGHT	H	1200 mm

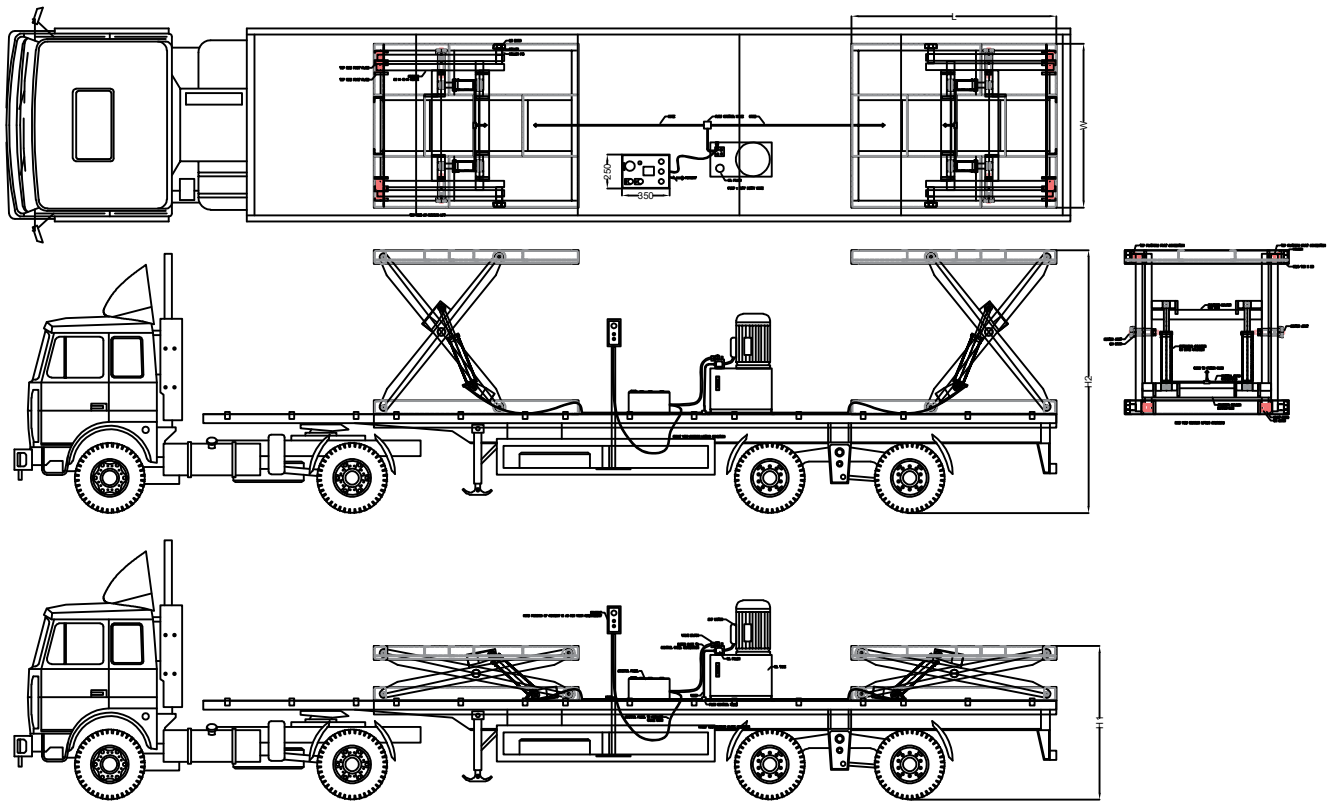

ALL DIMENSIONS ARE IN MM

CUSTOMER:~ M/S			
PRODUCT:~ ELE HYD SCISSOR LIFT (MOBILE)			
PROJECT:~3676_A		CAPACITY : 1500 KGS.	
COMP.FILE NO : GA DRAWING			
PROJECTION:~	SCALE:~ NTS	DATE	SIGN
	DRAWN	03.07.2020	RSG
	CHECKED	03.07.2020	ANIKET REV
	APPROVED	03.07.2020	PRATIK 00

JOIST-O-MECH
 (SINCE 1987)

THIS PRINT IS THE PROPERTY OF
 M/S JOIST-O-MECH
 RETURNED UPON REQUEST THIS PART MUST
 NOT BE SOLD TO ANY OTHER CONCERN.

SIZE	A4
SHEET	1 OF 1