

CAPACITY	C	500 kg
TOTAL LENGTH	L	2000 mm
TOTAL WIDTH	W	1200 mm
MOTOR HP	M	1 HP
CLOSE HEIGHT	H1	1000 mm
LIFT HEIGHT	H2	3000 mm
GROUND CLEARANCE	H	90 mm

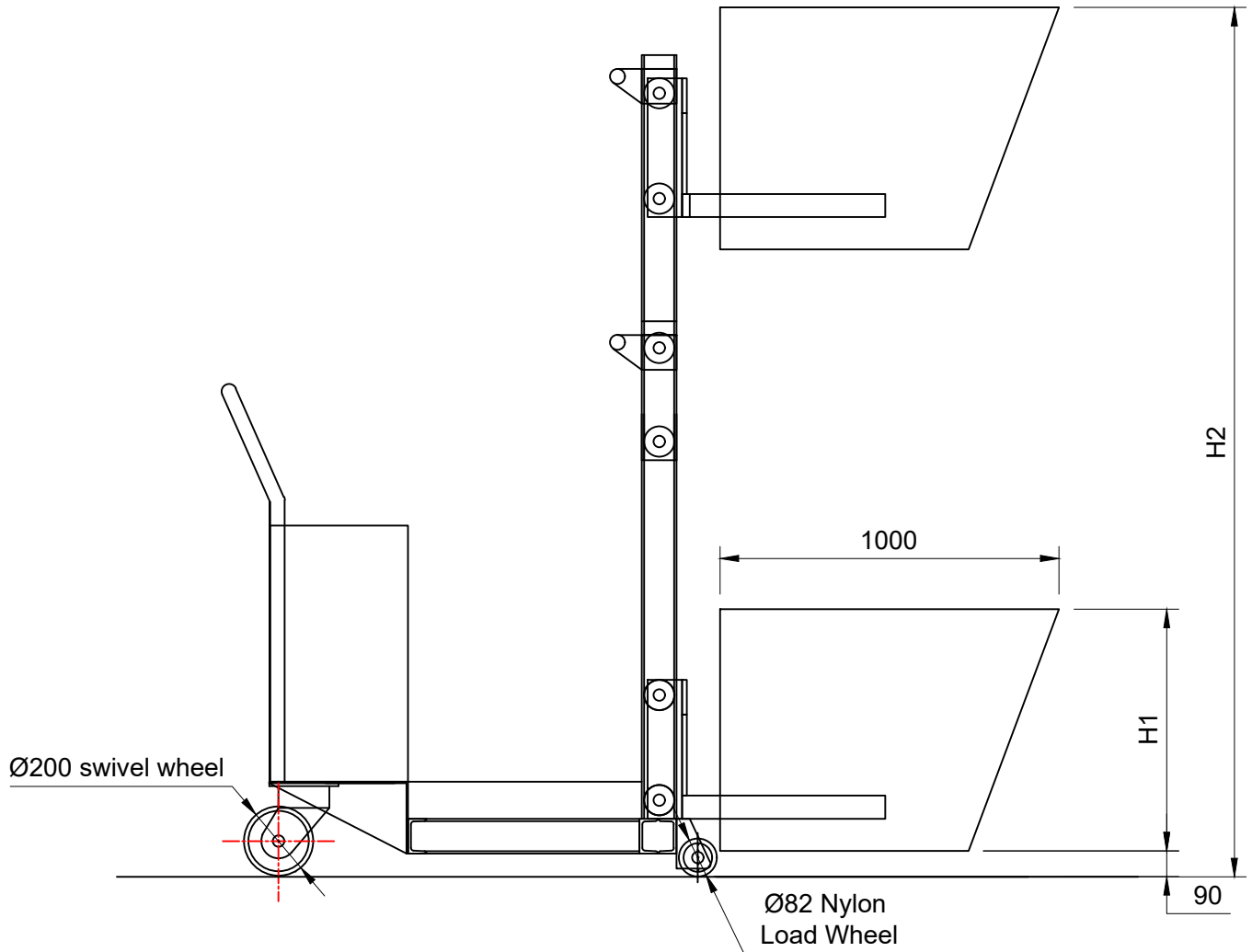
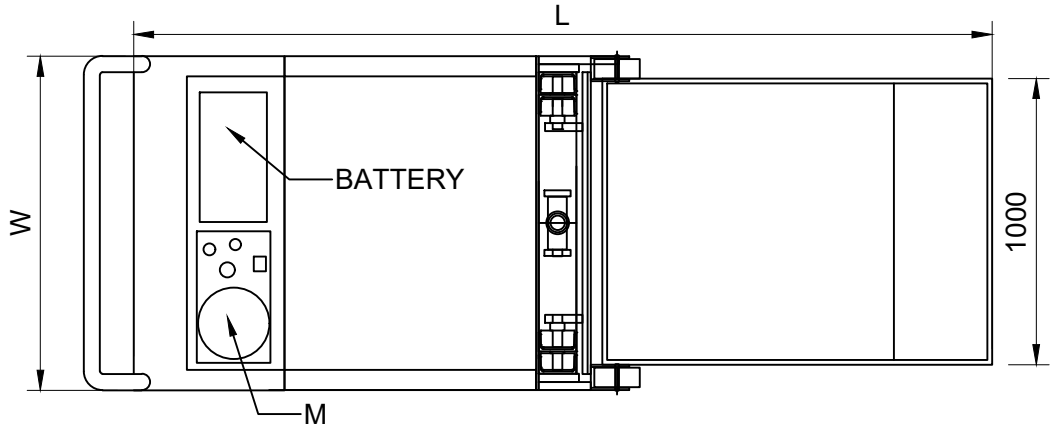

ALL DIMENSIONS ARE IN MM

CUSTOMER:~ M/S BERGER PAINTS JAMMU				
PRODUCT:~ BATTERY OPERATED BUCKET TILTING STACKER				
PROJECT:-2354		CAPACITY : 500 KGS.		
COMP.FILE NO : GA DRAWING				
PROJECTION:~	SCALE:~ NTS	DATE	SIGN	
	DRAWN	10.02.2020	PRATIK	
	CHECKED	10.02.2020	PRATIK	REV
	APPROVED	10.02.2020	JOSHI	00

JOIST-O-MECH
(SINCE 1987)

THIS PRINT IS THE PROPERTY OF
M/S JOIST-O-MECH
RETURNED UPON REQUEST THIS PART MUST
NOT BE SOLD TO ANY OTHER CONCERN.

SIZE	A4
SHEET	1 OF 1